

# XILAM

PANNELLI STRUTTURALI A STRATI INCROCIATI PER PARETI E SOLAI  
A DISTINTA, STANDARD, LAVORATI SU DISEGNO

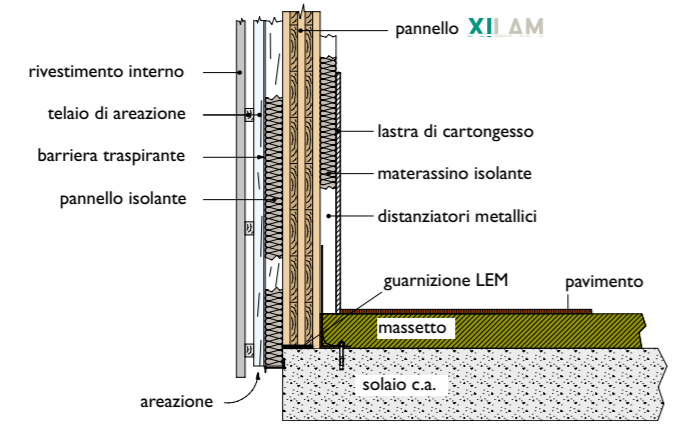

# SISTEMI COSTRUTTIVI

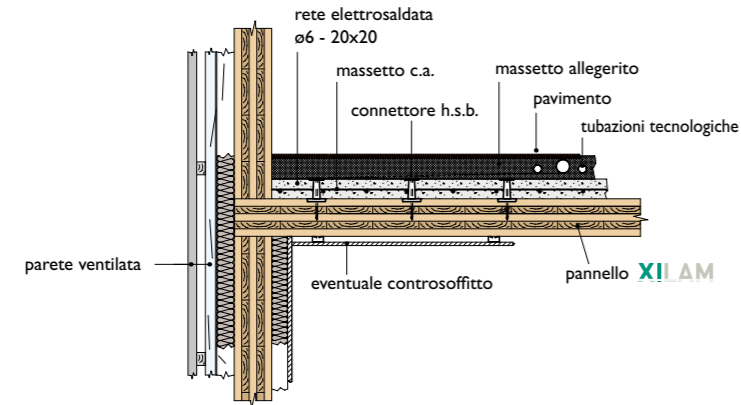
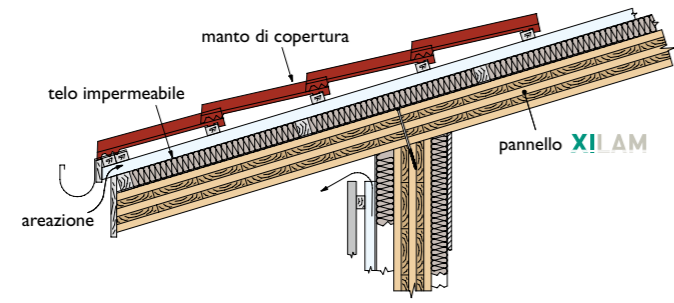
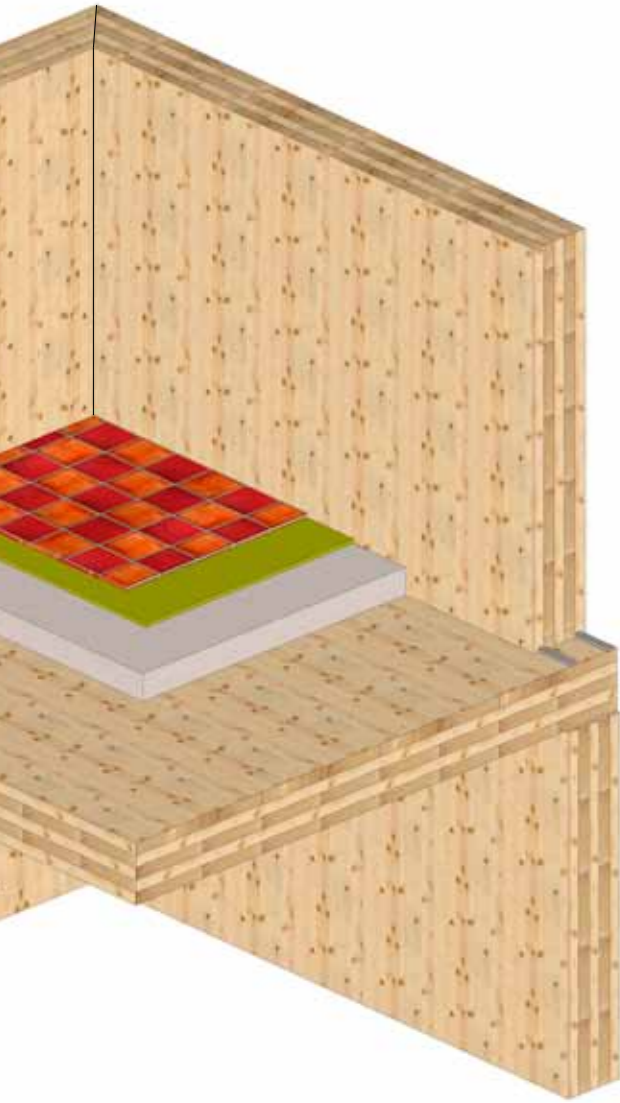

## GIUNZIONI PANNELLI PER PIANO

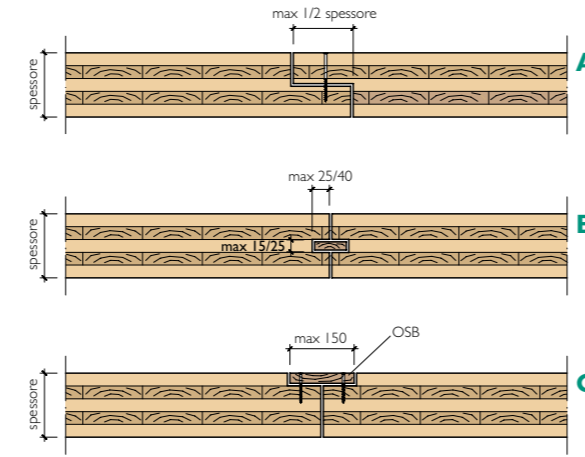

## GIUNZIONI PANNELLI SOLAIO\_PARETE

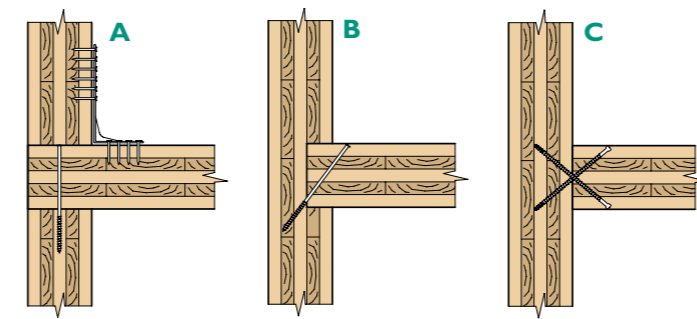

## GIUNZIONI PANNELLI AD ANGOLO

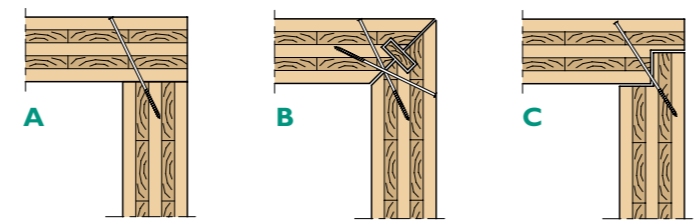

## DIAGRAMMI STATICI

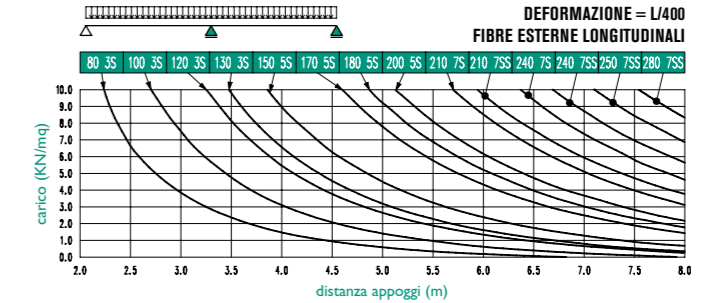
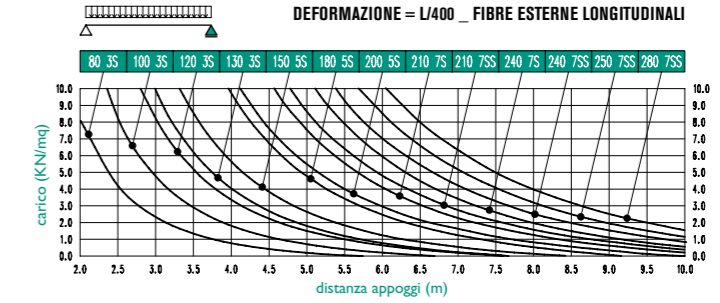
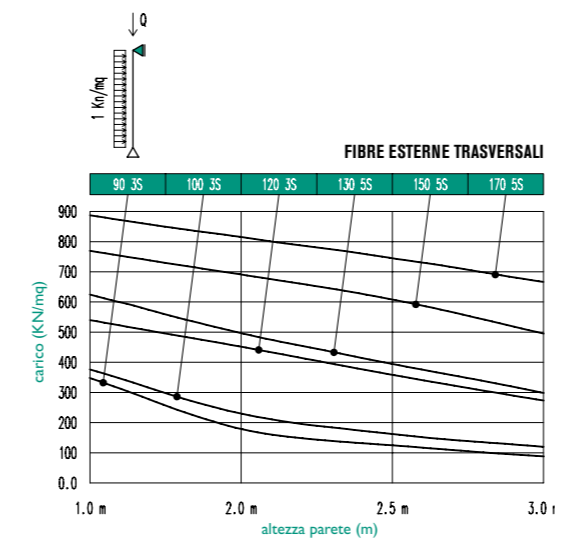
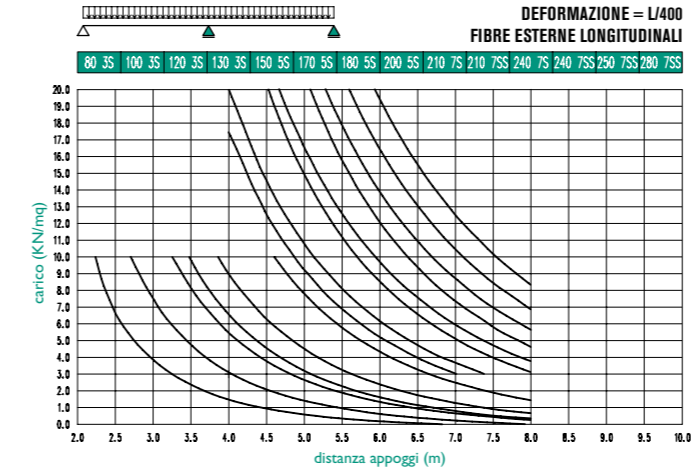
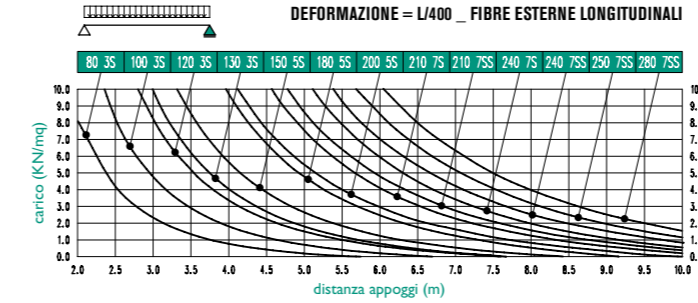

## FORMATI DISPONIBILI

nr. strati	spessore strati (20 - 30 - 40 mm)					spessore pannello	peso proprio kg/mq	dimensioni max in mm	
3			20	20	20	60	27,6	spessore 280 larghezza 3000 lunghezza 16500	
			20	30	20	70	32,2		
			20	40	20	80	36,8		
			30	30	30	90	41,4		
			30	40	30	100	46,0		
5			40	40	40	120	55,2		
		20	30	20	30	20	120		55,2
		30	20	30	20	30	130		59,8
		30	30	30	40	30	150		69,0
		40	30	40	30	40	170		78,2
7		40	40	40	40	40	200	92,0	
	30	30	30	30	30	30	210	96,6	
	30	40	30	40	30	40	30	240	110,4
	40	30	40	30	40	30	40	250	115,0
	40	40	40	40	40	40	40	280	128,8

A richiesta possono essere prodotti con 2 strati esterni a fibre parallele  
A seconda dell'utilizzo finale può essere scelto l'orientamento degli strati: longitudinale o trasversale (L/T)

> Siti produttivi  
Stabilimenti

Hermsdorf D

Mondolfo PU

Ascoli Piceno

Edolo BS

Braone BS

Bazzano AQ



**ALBERTANI**  
CORPORATES SPA

sede legale e amministrativa

I-25125 **Brescia**

Via Corsica 143

Tel +39 030 2427893

Fax +39 030 2450903

[www.albertani.com](http://www.albertani.com)

uffici commerciali

e stabilimento di produzione

61037 **Mondolfo** (Pu)

Viale dell'Industria, 6

Tel +39 0721 93691

Fax +39 0721 930158

[info@tecsol.it](mailto:info@tecsol.it)

[www.tecsol.it](http://www.tecsol.it)

Certificazioni CE - ISO 9001 - ISO 14001

